

# MHDSH445

规格  
Size  $\phi 1 \sim \phi 4$



无限白金Plus涂层 高硬度钢材用4刃平底铣刀

共有10种规格  
Total 10 sizes

采用可抑制倾斜的高刚性设计,加工最高70HRC的淬火钢时  
也可实现延长刀具寿命

High rigidity tool design suppresses deflection and realizes long tool life  
on machining 70HRC hardened steel

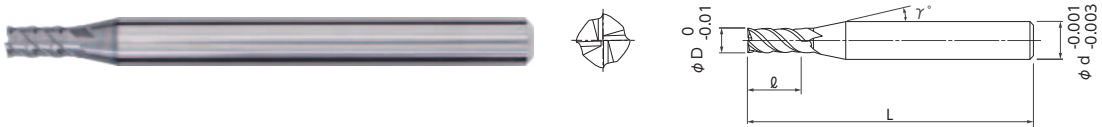
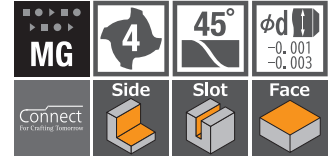

- 4刃铣刀为刃长2D、3D造型的产品。
- 采用无限白金Plus涂层,加工70HRC的高硬度钢时也可实现延长刀具寿命。
- 采用高刚性设计,可提高加工精度。
- 4-flute is lineup of length of cut expands 2D and 3D.
- MUGEN COATING PREMIUM Plus realizes long tool life even for hardened steel up to 70HRC.
- High rigidity tool design improves machining accuracy.

其他公司产品  
Other tool brand  
0.018 mm

MHDSH645  
0.010 mm

倾斜量  
Deflection amount

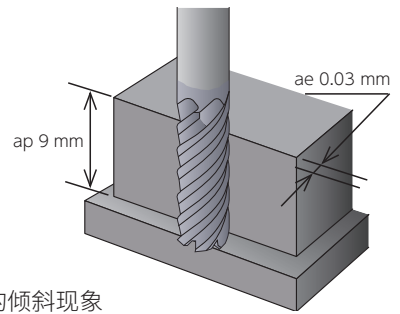

采用高刚性设计,可抑制加工高硬度钢时发生的倾斜现象  
Unequal spacing suppresses chattering even high feed rate machining

单位[规格:mm/价格:日元]  
Unit [Size : mm / Retail Price : JPY]

产品代码 Code No.	(D)外径 Dia.	(ℓ)刃长 Length of Cut	(γ)颈角 Neck Taper Angle	(d)柄径 Shank Dia.	(L)全长 Overall Length	定价(日元) Retail Price
08-00429-00102	1	2	12°	6	60	7,500
08-00429-00103		3	12°	6	60	7,700
08-00429-00152	1.5	3	12°	6	60	7,500
08-00429-00153		4.5	12°	6	60	7,700
08-00429-00202	2	4	12°	6	60	7,500
08-00429-00203		6	12°	6	60	7,700
08-00429-00302	3	6	12°	6	60	8,700
08-00429-00303		9	12°	6	60	8,900
08-00429-00402	4	8	12°	6	60	9,400
08-00429-00403		12	12°	6	60	9,700

订购方法  
How to Order

请指定MHDSH445 外径(D)×刃长(ℓ)。 ※(γ)为参考值。  
When you order, indicate MHDSH445(D)×(ℓ). ※(γ) is reference value.

平底 全刃长  
Full Cutting Length  
Square 涂层  
Coating

常规系列  
无限白金Plus涂层  
Regular Line  
MUGEN PREMIUM Plus