

RSES230

规格
Size $\phi 0.1 \sim \phi 6$

MG

树脂加工用平底铣刀“Clear Cut”短刃造型

共有109种规格
Total 109 sizes

树脂加工用平底铣刀。刃长短，刚性高

Square end mill for resin. High rigidity with short length of cut

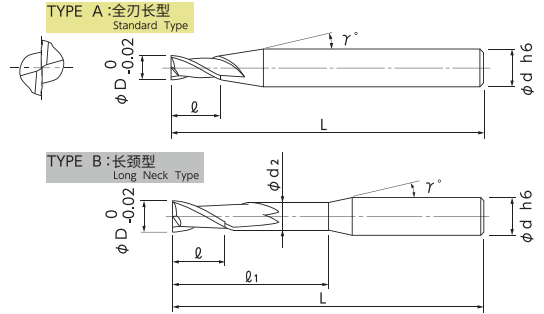
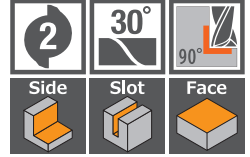

- 也可用于铝、铜等非金属金属材料。
- 采用短刃造型长，消除了传统产品刃长过长所带来的烦恼。
- Applicable to nonferrous material such as Aluminium and Copper.
- Eliminate the conventional problem of the long flute length.

单位 [规格:mm/价格:日元]
Unit [Size : mm / Retail Price : JPY]

产品代码 Code No.	(D)外径 Dia.	(l)刃长 Length of Cut	(l1)颈长 Under Neck Length	形状 Type	(d2)颈径 Neck Dia.	(γ)颈角 Neck Taper Angle	(d)柄径 Shank Dia.	(L)全长 Overall Length	定价(日元) Retail Price
01-00640-01000	0.1	0.15	-	A	-	9°	4	50	7,400
01-00640-01003			0.3	B	0.085	12°	4	50	8,000
01-00640-01005			0.5		0.085	12°	4	50	8,400
01-00640-01008			0.8		0.085	12°	4	50	9,200
01-00640-01010			1		0.085	12°	4	50	11,600
01-00640-01500	0.15	0.23	-	A	-	9°	4	50	6,700
01-00640-01505			0.5	B	0.13	12°	4	50	7,100
01-00640-01508			0.8		0.13	12°	4	50	7,900
01-00640-01510			1		0.13	12°	4	50	8,400
01-00640-01515			1.5		0.13	12°	4	50	10,500
01-00640-02000	0.2	0.3	-	A	-	9°	4	50	6,400
01-00640-02006			0.6	B	0.18	12°	4	50	7,400
01-00640-02010			1		0.18	12°	4	50	7,800
01-00640-02015			1.5		0.18	12°	4	50	9,500
01-00640-02020			2		0.18	12°	4	50	12,600
01-00640-03000	0.3	0.45	-	A	-	9°	4	50	5,700
01-00640-03010			1	B	0.28	12°	4	50	6,600
01-00640-03015			1.5		0.28	12°	4	50	6,800
01-00640-03020			2		0.28	12°	4	50	7,600
01-00640-03025			2.5		0.28	12°	4	50	9,200
01-00640-03030	3	0.28	12°	4	50	11,600			
01-00640-04000	0.4	0.6	-	A	-	9°	4	60	6,200
01-00640-04015			1.5	B	0.37	12°	4	60	6,800
01-00640-04020			2		0.37	12°	4	60	6,800
01-00640-04025			2.5		0.37	12°	4	60	6,800

订购方法
How to Order

请指定RSES230 外径(D)×刃长(l) [×颈长(l1)]。(φ4的形状 A(全刃长型)需指定柄径(d)。
When you order, indicate RSES230 (D)×(l) [×(l1)]. Choose Shank Dia. (d) for Type A of Dia. 4.

※(γ)为参考值。

※(γ) is reference value.

树脂加工
Resin Milling

树脂加工用平底铣刀“Clear Cut”短刃造型

Short Flute End Mill for Resin

单位 [规格: mm / 价格: 日元]
Unit [Size : mm / Retail Price : JPY]

产品代码 Code No.	(D)外径 Dia.	(ℓ)刃长 Length of Cut	(ℓ ₁)颈长 Under Neck Length	形状 Type	(d ₂)颈径 Neck Dia.	(γ)颈角 Neck Taper Angle	(d)柄径 Shank Dia.	(L)全长 Overall Length	定价(日元) Retail Price
01-00640-04030	0.4	0.6	3	B	0.37	12°	4	60	7,400
01-00640-04035			3.5		0.37	12°	4	60	7,400
01-00640-04040			4		0.37	12°	4	60	8,400
01-00640-05000	0.5	0.75	-	A	-	9°	4	60	4,500
01-00640-05020			2	0.46	12°	4	60	4,700	
01-00640-05030			3	0.46	12°	4	60	4,700	
01-00640-05040			4	0.46	12°	4	60	4,700	
01-00640-05060			6	0.46	12°	4	60	4,700	
01-00640-05080			8	0.46	12°	4	60	7,100	
01-00640-05100			10	0.46	12°	4	60	8,400	
01-00640-05120			12	0.46	12°	4	60	8,900	
01-00640-06000	0.6	0.9	-	A	-	9°	4	60	5,100
01-00640-06030			3	0.56	12°	4	60	5,300	
01-00640-06040			4	0.56	12°	4	60	5,300	
01-00640-06060			6	0.56	12°	4	60	5,600	
01-00640-06080			8	0.56	12°	4	60	7,900	
01-00640-06100			10	0.56	12°	4	60	8,500	
01-00640-07000	0.7	1.05	-	A	-	9°	4	60	5,100
01-00640-07040			4	0.66	12°	4	60	5,300	
01-00640-07060			6	0.66	12°	4	60	5,300	
01-00640-08000	0.8	1.2	-	A	-	9°	4	60	5,100
01-00640-08040			4	0.76	12°	4	60	5,300	
01-00640-08060			6	0.76	12°	4	60	5,300	
01-00640-08080			8	0.76	12°	4	60	5,500	
01-00640-08100			10	0.76	12°	4	60	6,000	
01-00640-08120			12	0.76	12°	4	60	6,700	
01-00640-08140			14	0.76	12°	4	60	6,700	
01-00640-08160			16	0.76	12°	4	60	6,700	
01-00640-09000	0.9	1.35	-	A	-	9°	4	60	5,100
01-00640-09060			6	0.86	12°	4	60	5,300	
01-00640-09080			8	0.86	12°	4	60	5,300	
01-00640-10000	1	1.5	-	A	-	9°	4	70	4,200
01-00640-10040			4	0.95	12°	4	70	4,400	
01-00640-10060			6	0.95	12°	4	70	4,400	
01-00640-10080			8	0.95	12°	4	70	4,400	
01-00640-10100			10	0.95	12°	4	70	5,000	
01-00640-10120			12	0.95	12°	4	70	5,000	
01-00640-10140			14	0.95	12°	4	70	5,000	
01-00640-10150			15	0.95	12°	4	70	5,000	
01-00640-10180			18	0.95	12°	4	70	5,700	
01-00640-10200			20	0.95	12°	4	70	6,300	

N 铝合金
Aluminium Alloy ○N 铜合金
Copper ○O 树脂
Resin ⊙

平底
Square
全刃长
Full Cutting Length
长颈
Long Neck
无涂层
Non-Coating

RSES230

树脂加工用平底铣刀“Clear Cut”短刃造型

Short Flute End Mill for Resin

单位 [规格: mm / 价格: 日元]
Unit [Size: mm / Retail Price: JPY]

产品代码 Code No.	(D)外径 Dia.	(ℓ)刃长 Length of Cut	(ℓ ₁)颈长 Under Neck Length	形状 Type	(d ₂)颈径 Neck Dia.	(γ)颈角 Neck Taper Angle	(d)柄径 Shank Dia.	(L)全长 Overall Length	定价(日元) Retail Price			
01-00640-15000	1.5	2.25	-	A	-	9°	4	70	4,200			
01-00640-15060			6	B	1.45	12°	4	70	4,700			
01-00640-15080			8		1.45	12°	4	70	4,700			
01-00640-15100			10		1.45	12°	4	70	5,100			
01-00640-15120			12		1.45	12°	4	70	5,100			
01-00640-15150			15		1.45	12°	4	70	5,100			
01-00640-15180			18		1.45	12°	4	70	5,100			
01-00640-15200			20		1.45	12°	4	70	6,100			
01-00640-15230			23		1.45	12°	4	70	6,100			
01-00640-15250			25		1.45	12°	4	70	7,400			
01-00640-15300			30		1.45	12°	4	70	7,400			
01-00640-20000			2		3	-	A	-	9°	4	60	3,700
01-00640-20060	6	B				1.94	12°	4	60	4,000		
01-00640-20080	8			1.94		12°	4	60	4,000			
01-00640-20100	10			1.94		12°	4	60	4,000			
01-00640-20120	12			1.94		12°	4	60	4,000			
01-00640-20150	15			1.94		12°	4	60	4,000			
01-00640-20200	20			1.94		12°	4	80	5,000			
01-00640-20240	24			1.94		12°	4	80	5,400			
01-00640-20300	30			1.94		12°	4	80	5,400			
01-00640-20400	40			1.94		12°	4	100	8,900			
01-00640-30000	3			4.5		-	A	-	-	3	80	6,300
01-00640-30100						10	B	2.85	12°	6	80	6,100
01-00640-30120			12		2.85	12°		6	80	6,100		
01-00640-30150		15	2.85		12°	6		80	6,100			
01-00640-30200		20	2.85		12°	6		80	6,600			
01-00640-30240		24	2.85		12°	6		80	7,200			
01-00640-30300		30	2.85		12°	6		80	7,200			
01-00640-30360		36	2.85		12°	6		80	7,200			
01-00640-40000	4	6	-	A	-	-		4	80	7,800		
01-00640-40001			-	B	-	9°	6	80	6,600			
01-00640-40100			10		3.8	12°	6	80	6,600			
01-00640-40150			15		3.8	12°	6	80	6,600			
01-00640-40200			20		3.8	12°	6	80	6,600			
01-00640-40300			30		3.8	12°	6	80	7,200			
01-00640-40400			40		3.8	12°	6	100	8,000			
01-00640-50000			5		7.5	-	A	-	9°	6	80	6,400
01-00640-50300	30	B				4.8	12°	6	80	7,200		
01-00640-50400	40			4.8		12°	6	100	7,500			
01-00640-60000	6	9	-	A	-	-	6	90	6,400			
01-00640-60400			40	B	5.8	-	6	90	8,000			
01-00640-60600			60		5.8	-	6	120	10,600			
01-00640-60800			80		5.8	-	6	150	17,600			

订购方法
How to Order

请指定RSES230 外径(D)×刃长(ℓ)[×颈长(ℓ₁)]. (φ4的形状 A(全刃长型)需指定柄径(d).)
When you order, indicate RSES230 (D)×(ℓ) [×(ℓ₁)]. Choose Shank Dia. (d) for Type A of Dia. 4.

※(γ)为参考值。
※(γ) is reference value.

- 铝合金 Aluminium Alloy **N**
- 铜合金 Copper **N**
- ◎ 树脂 Resin **O**

树脂加工
Resin Milling